

PRO-FORM

SR 30

Model No. 831.283170

Serial No. _____

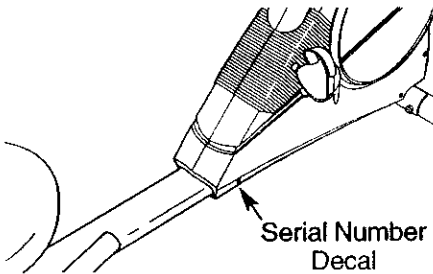

EXERCISE
EQUIPMENT

QUESTIONS

HELPLINE!

1-800-736-6879

SEARS, ROEBUCK AND CO.,
HOFFMAN ESTATES, IL 60179

CAUTION

Read all precautions and instructions in this manual before using this equipment. Keep this manual for future reference.

USER'S MANUAL

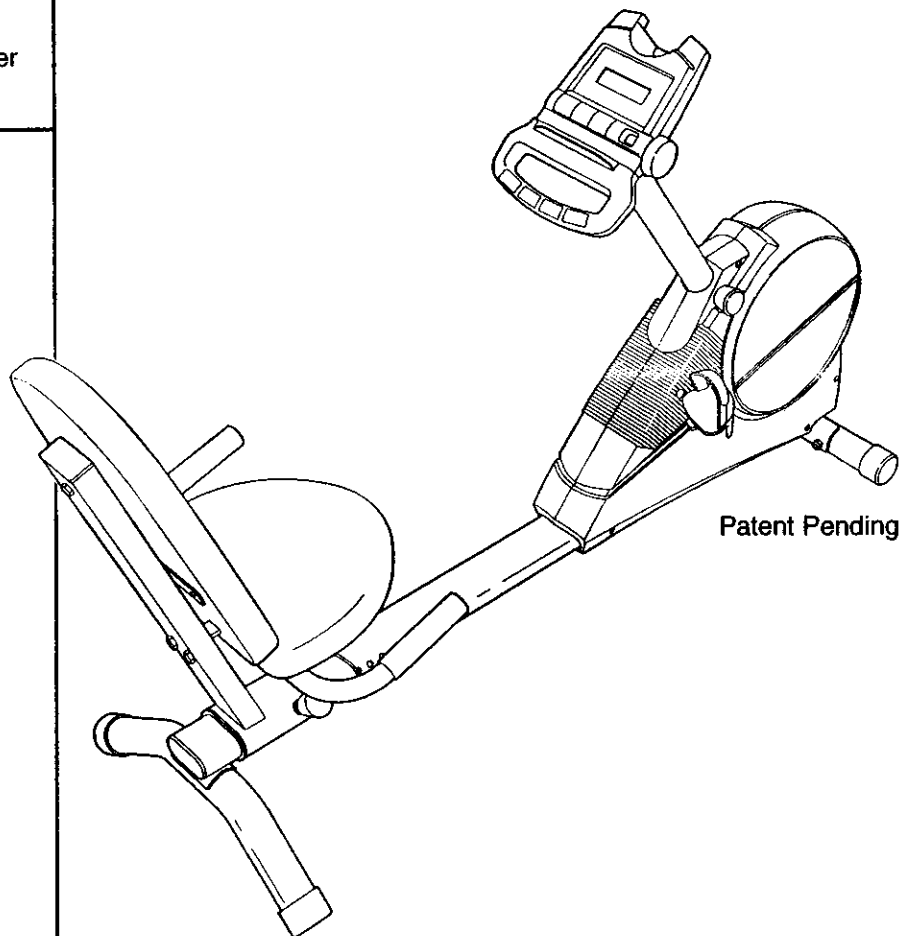

Visit our website at

www.proform.com

*new products, prizes,
fitness tips, and much more!*

TABLE OF CONTENTS

IMPORTANT PRECAUTIONS	2
BEFORE YOU BEGIN	3
ASSEMBLY	4
HOW TO OPERATE THE EXERCISE CYCLE	8
MAINTENANCE AND TROUBLESHOOTING	11
CONDITIONING GUIDELINES	12
PART LIST	14
EXPLODED DRAWING	15
HOW TO ORDER REPLACEMENT PARTS	Back Cover
FULL 90 DAY WARRANTY	Back Cover

IMPORTANT PRECAUTIONS

⚠ WARNING: To reduce the risk of serious injury, read the following important precautions before using the exercise cycle.

1. Read all instructions in this manual before using the exercise cycle.
2. It is the responsibility of the owner to ensure that all users of the exercise cycle are adequately informed of all precautions. Use the exercise cycle only as described in this manual.
3. Use the exercise cycle indoors on a level surface. Keep the exercise cycle away from moisture and dust. Place a mat under the exercise cycle to protect the floor.
4. Inspect and properly tighten all parts regularly. Replace any worn parts immediately.
5. Keep children under the age of 12 and pets away from the exercise cycle at all times.
6. Wear appropriate clothes when exercising; do not wear loose clothes that could become caught on the exercise cycle. Always wear athletic shoes for foot protection.
7. The exercise cycle should not be used by persons weighing more than 250 pounds.
8. Always keep your back straight when using the exercise cycle; do not arch your back.
9. If you feel pain or dizziness while exercising, stop immediately and cool down.
10. The exercise cycle does not have a free wheel; the pedals will continue to move until the fly-wheel stops.
11. The pulse sensor is not a medical device. Various factors, including the user's movement, may affect the accuracy of heart rate readings. The pulse sensor is intended only as an exercise aid in determining heart rate trends in general.
12. The exercise cycle is intended for home use only. Do not use the exercise cycle in a commercial, rental, or institutional setting.

⚠ WARNING: Before beginning this or any exercise program, consult your physician. This is especially important for persons over the age of 35 or persons with pre-existing health problems. Read all instructions before using. SEARS assumes no responsibility for personal injury or property damage sustained by or through the use of this product.

BEFORE YOU BEGIN

Congratulations for selecting the new PROFORM® SR 30 exercise cycle. Cycling is one of the most effective exercises for increasing cardiovascular fitness, building endurance, and toning the entire body. The PROFORM® SR 30 exercise cycle offers a selection of features designed to let you enjoy this healthful exercise in the convenience and privacy of your home.

For your benefit, read this manual carefully before you use the exercise cycle. If you have questions after reading this manual, please call our toll-free

HELPLINE at 1-800-736-6879, Monday through Saturday, 7 a.m. until 7 p.m. Central Time (excluding holidays). To help us assist you, please note the product model number and serial number before calling. The model number is 831.283170. The serial number can be found on a decal attached to the exercise cycle (see the front cover of this manual).

Before reading further, please familiarize yourself with the parts that are labeled in the drawing below.

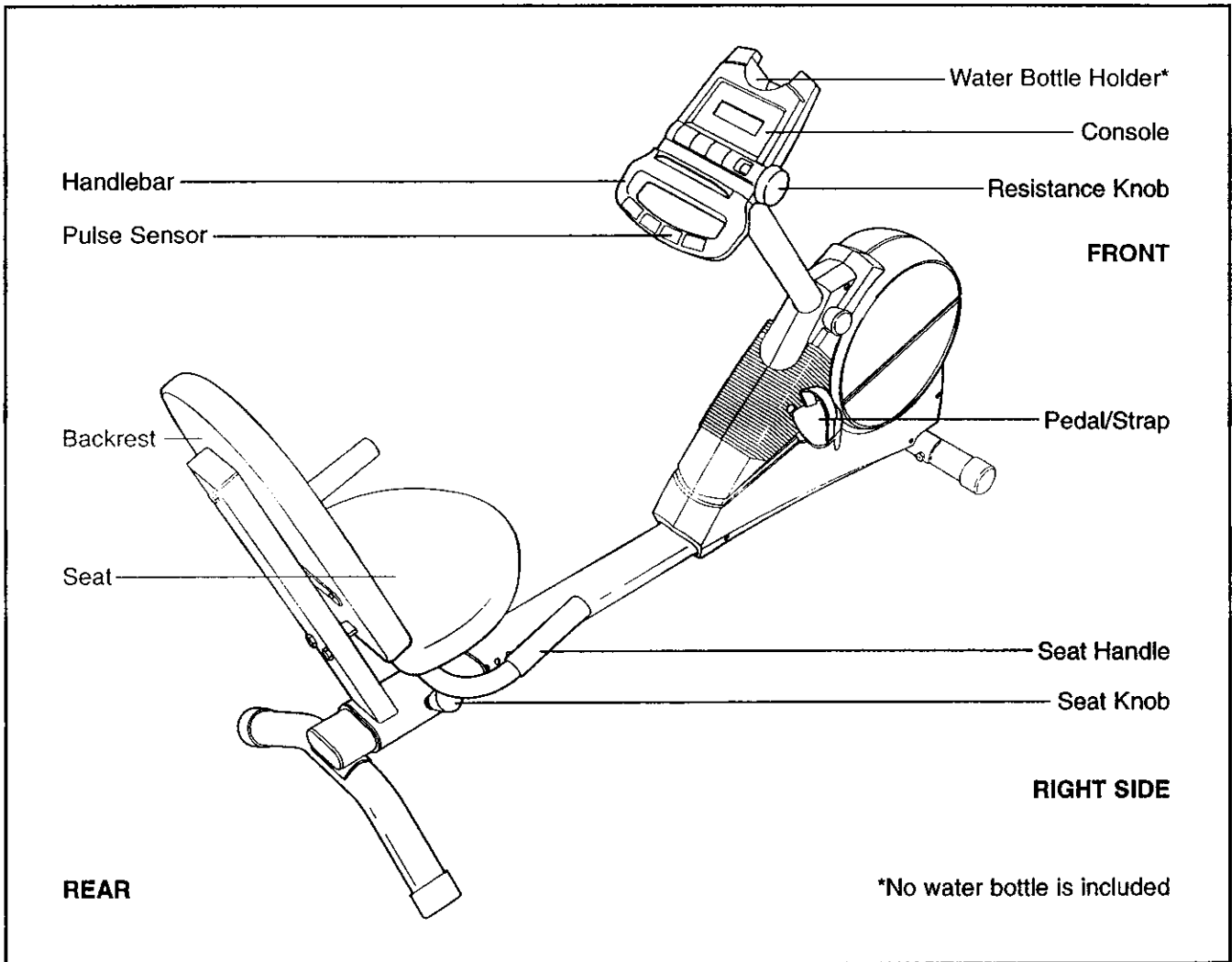

ASSEMBLY

Assembly requires two persons. Place all parts of the exercise cycle in a cleared area and remove the packing materials. Do not dispose of the packing materials until assembly is completed.

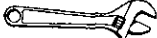
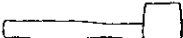
In addition to the included allen wrenches, assembly requires a phillips screwdriver  , an adjustable wrench  , and a rubber mallet .

As you assemble the exercise cycle, use the drawings below to identify the small parts used in assembly. The number in parenthesis below each drawing refers to the key number of the part, from the PART LIST on page 14. The second number refers to the quantity used in assembly. **Note: Some small parts may have been pre-assembled for shipping. If a part is not in the parts bag, check to see if it has been pre-assembled.**

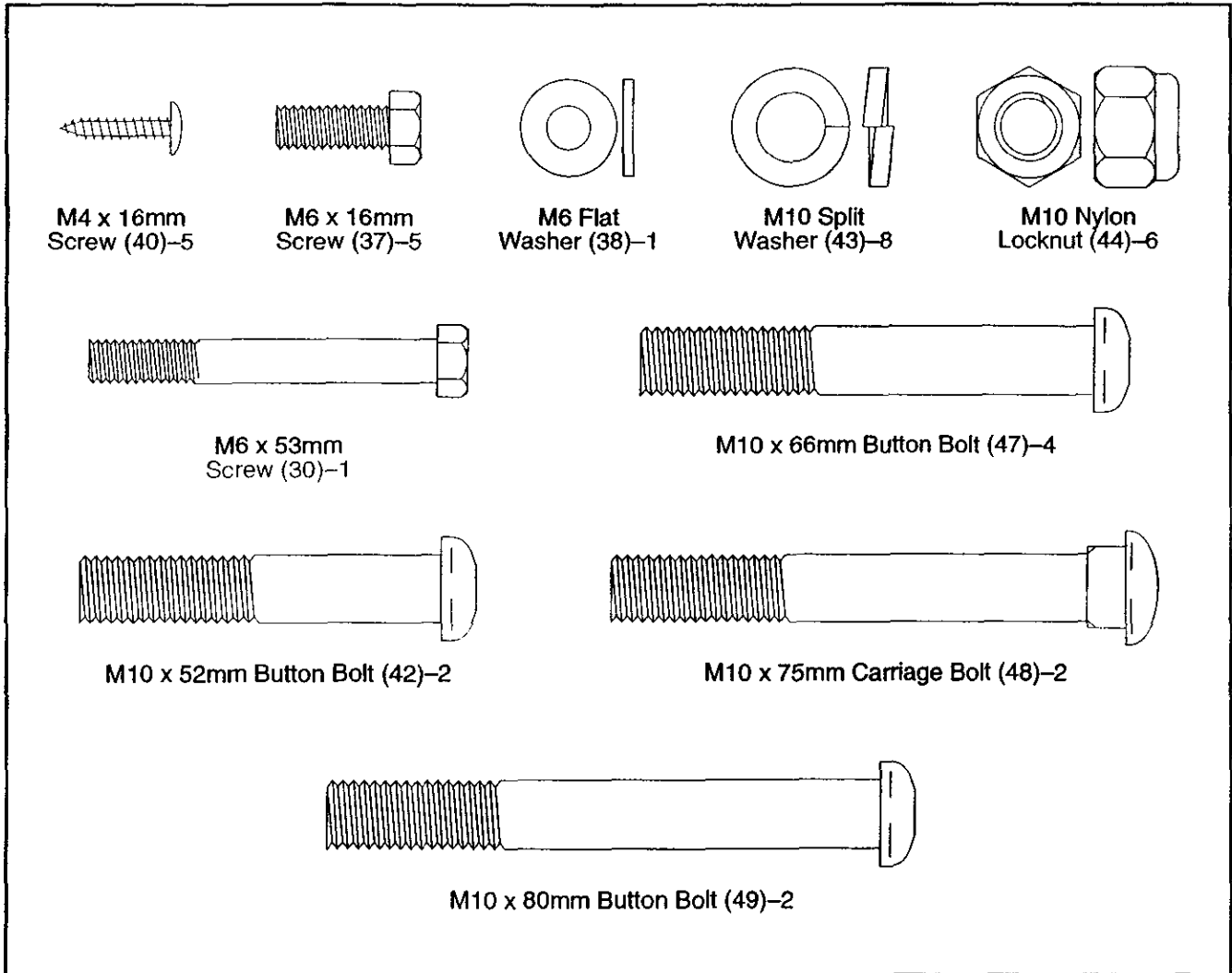

1. Identify the Front Stabilizer (2). While another person lifts the front of the Frame (1) slightly, attach the Front Stabilizer to the Frame with two M10 x 75mm Carriage Bolts (48) and two M10 Nylon Locknuts (44).

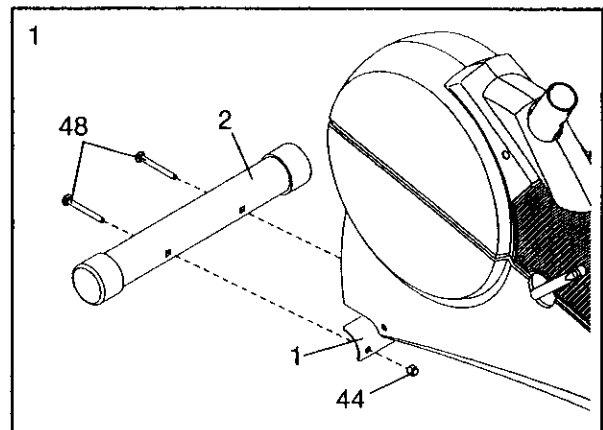

2. Orient the Frame Rail (3) as shown. Attach the Rear Stabilizer (5) to the Frame Rail with two M10 x 80mm Button Bolts (49) and two M10 Split Washers (43).

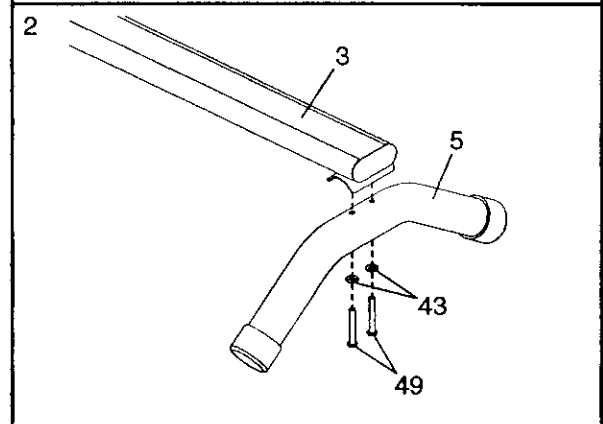

3. Locate the Seat Knob (not shown) on the Seat Carriage (4). Turn the Seat Knob counterclockwise two or three turns to loosen it. Next, pull the Knob, slide the Seat Carriage onto the Frame Rail (3), and then release the Knob. Make sure that the Seat Carriage is oriented as shown. Move the Seat Carriage back and forth slightly until it locks into position. Then, tighten the Knob.

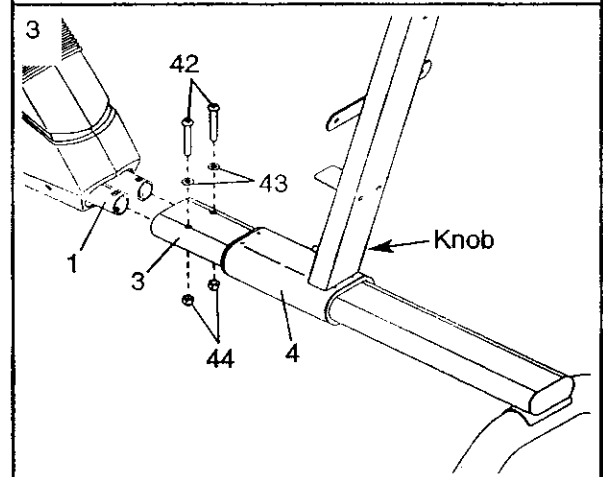

Slide the Frame Rail (3) onto the indicated round tubes on the Frame (1). Attach the Frame Rail with two M10 x 52mm Button Bolts (42), two M10 Split Washers (43), and two M10 Nylon Locknuts (44).

4. Attach the Seat (10) to the Seat Frame (6) with three M6 x 16mm Screws (37).

Press the Seat Endcap (56) into the Seat Frame (6).

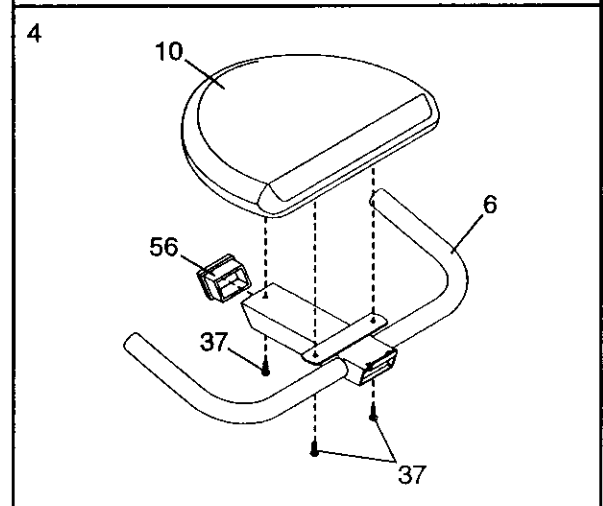

5. Hold the Seat Frame (6) at an angle, and insert the tab on the Seat Frame into the indicated slot in the Seat Carriage (4). Attach the Seat Frame to the Seat Carriage with two M10 x 66mm Button Bolts (47) and two M10 Split Washers (43).

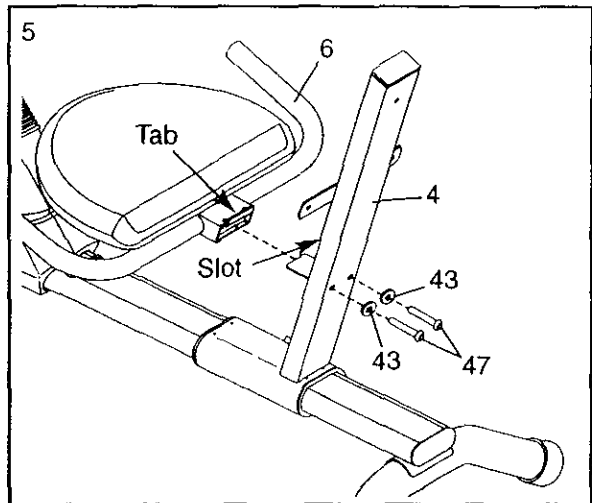

6. Attach the Backrest (9) to the Seat Carriage (4) with two M6 x 16mm Screws (37), an M6 x 53mm Screw (30), and an M6 Flat Washer (38) as shown.

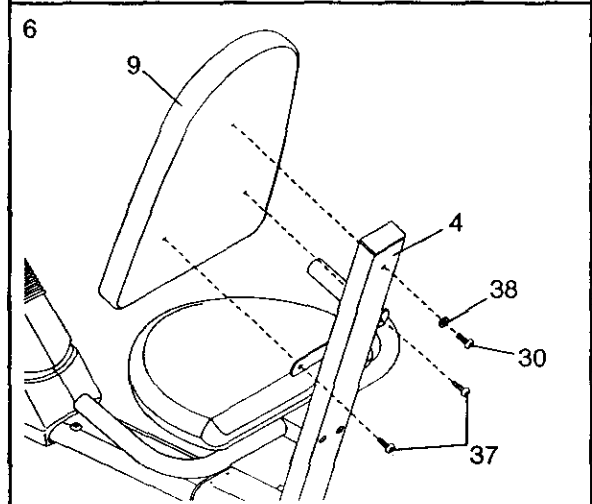

7. The Console (12) requires three "AA" batteries (not included); alkaline batteries are recommended. Insert three batteries into the Console as shown. **Make sure that the batteries are oriented as shown by the diagram inside the Console.**

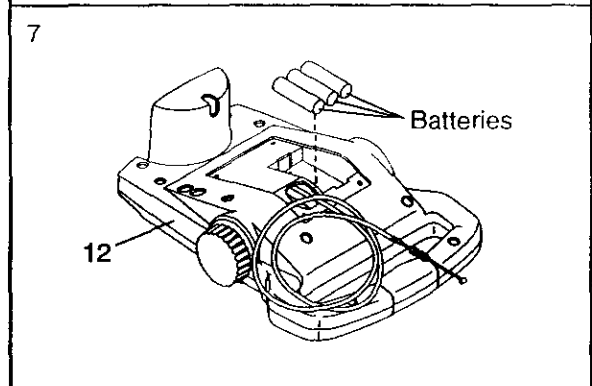

8. Hold the Console (12) near the Upright (11). Insert the console cable and the console wire into the indicated hole and down through the Upright. Attach the ground wire to the Upright with an M4 x 16mm Screw (40).

Insert the excess wire and cable into the Upright (11). Attach the Console (12) to the Upright with four M4 x 16mm Screws (40). **Make sure that the wires and the cable are not pinched.**

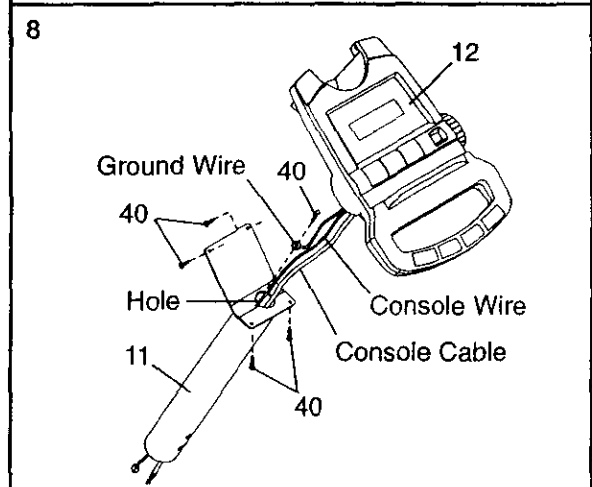

9. While another person holds the Upright (11) in the position shown, connect the console wire to the Reed Switch Wire (46). Next, connect the console cable to the Lower Cable (32) in the following way:

- Refer to inset drawing A. Pull up on the metal bracket on the Lower Cable (32), and insert the tip of the console cable (CC) into the wire clip inside of the metal bracket.
- Refer to inset drawing B. **Firmly** pull the console cable (CC) and slide it into the metal bracket on the Lower Cable (32) as shown.
- Refer to inset drawing C. Using pliers, squeeze the prongs on the upper end of the metal bracket together.

Insert the excess wire and cable down into the Frame (1). Slide the Upright (11) onto the Frame. **Make sure that the wires and cables are not pinched.** Attach the Upright to the Frame with two M10 x 66mm Button Bolts (47), two M10 Split Washers (43), and two M10 Nylon Locknuts (44).

10. Identify the Left Pedal (20), which is marked with an "L." Using an adjustable wrench, **firmly tighten the Left Pedal counterclockwise** into the left arm of the Crank (14). Tighten the Right Pedal (not shown) *clockwise* into the right arm of the Crank. **Important: Tighten both Pedals as firmly as possible. After using the exercise cycle for one week, retighten the Pedals. For best performance, the Pedals must be kept tightened.**

Adjust the left Pedal Strap (21) to the desired position, and press the end of the Pedal Strap onto the tab on the side of the Left Pedal (20). Adjust the other Pedal Strap (not shown) in the same way.

11. **Make sure that all parts of the exercise cycle are properly tightened.** Note: Some hardware may be left over after assembly is completed. To protect the floor or carpet from damage, place a mat under the exercise cycle.

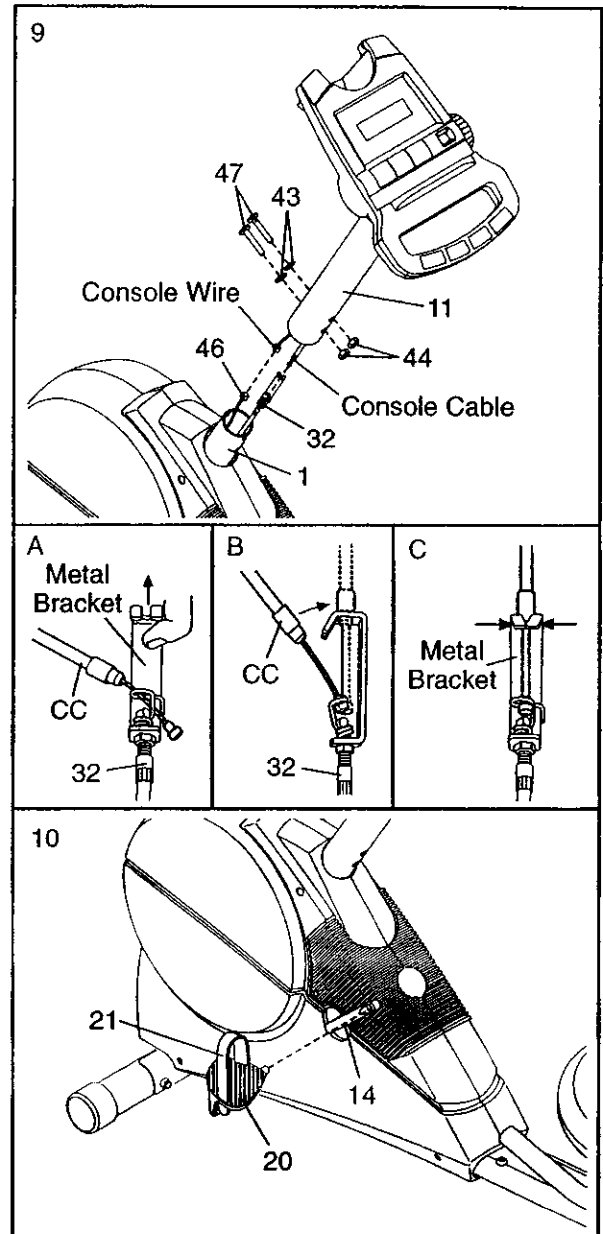

HOW TO OPERATE THE EXERCISE CYCLE

HOW TO ADJUST THE SEAT

For effective exercise, the seat should be in the proper position. As you pedal, there should be a slight bend in your knees when the pedals are at the point farthest from you. To adjust the seat, first turn the seat knob counterclockwise two or three turns to loosen it (if the knob is not loosened enough, it may scratch the frame rail). Next, pull the knob, slide the seat carriage to the desired position, and then release the knob. **Move the seat carriage back and forth slightly until the pin on the knob snaps into one of the holes in the frame rail.** Then, turn the knob clockwise until it is tight.

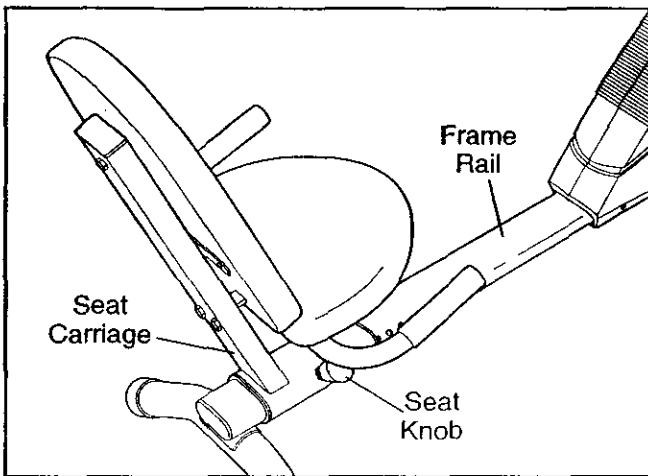

HOW TO ADJUST THE PEDALING RESISTANCE

To adjust the pedaling resistance, turn the resistance knob on the console. Numbers beside the knob will show which resistance level is selected.

Important: Stop turning the knob when turning becomes difficult, or the console may become damaged.

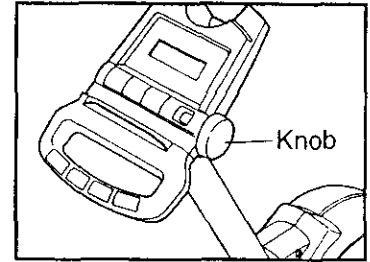

HOW TO ADJUST THE PEDAL STRAPS

To adjust the pedal straps, first pull the ends of the pedal straps off the tabs on the pedals. Adjust the pedal straps to the desired position, and then press the ends of the pedal straps back onto the tabs.

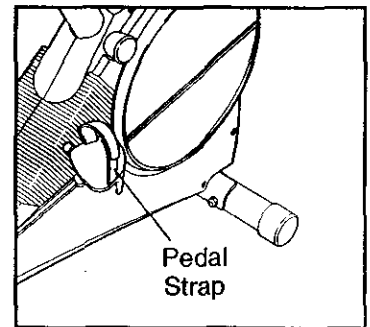

FEATURES OF THE CONSOLE

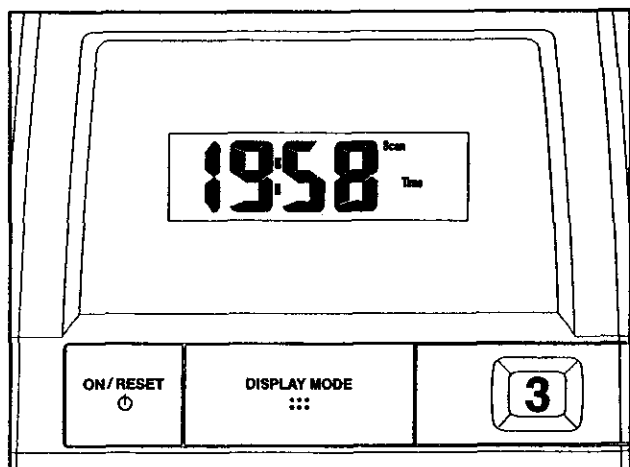

The easy-to-use console features seven modes that provide instant exercise feedback during your workouts. The modes are described below.

Speed—This mode displays your pedaling speed.

Time—This mode displays the elapsed time. **Note:** When you stop pedaling for a few seconds, the time mode will pause.

Distance—This mode displays the distance you have pedaled.

Calories—This mode displays the approximate number of calories you have burned.

Fat Calories—This mode displays the approximate number of fat calories you have burned (see **FAT BURNING** on page 12).

Scan—This mode displays the speed, time, distance, calorie, and fat calorie modes, for a few seconds each, in a repeating cycle.

Pulse (BPM)—This mode displays your heart rate when you use the pulse sensor.

Note: The console can display speed and distance in either miles or kilometers. To change the unit of measurement, hold down the On/Reset button for a few seconds. The mode indicators will show which unit of measurement is selected. When the batteries are replaced, it may be necessary to reselect the desired unit of measurement.

HOW TO OPERATE THE CONSOLE

Make sure that there are batteries in the console (see **BATTERY REPLACEMENT** on page 11). If there is a thin sheet of clear plastic on the console, remove it.

Follow the steps below to operate the console.

1. To turn on the power, press the On/Reset button or simply begin pedaling. When the power is turned on, the entire display will appear for two seconds. The console will then be ready for use.

2. Select one of the modes:

Scan mode—

When the power is turned on, the scan mode will automatically be selected. The scan indicator will appear in the display to show that the scan mode is selected, and a second mode indicator will show which mode is currently displayed. **Note:** If a different mode is selected, you can select the scan mode again by repeatedly pressing the Display Mode button.

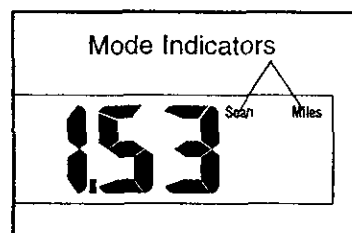

Speed, time, distance, calories, or fat calories mode—

To select one of these modes for continuous display, press the Display Mode button repeatedly until only the MPH (or Km/H), Time, Miles (or Kms), Cals., or Fat Cals. indicator appears in the display. Make sure that the Scan indicator does not appear.

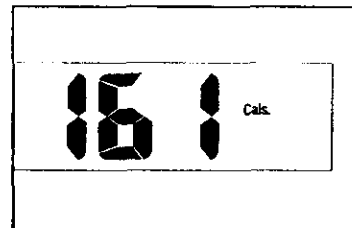

To reset the display, press the On/Reset button.

3. Measure your heart rate if desired.

Note: If there are thin sheets of plastic on the four metal contacts of the pulse sensor, peel off the plastic.

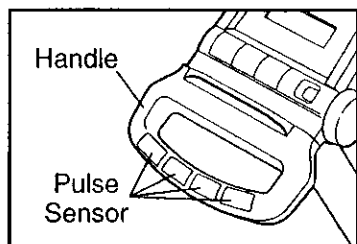

To use the pulse sensor, hold the handle on the console, with your right palm covering the two right contacts and your left palm covering the two left contacts. Avoid moving your hands. When your pulse is detected, the heart-shaped indicator in the display will flash each time your heart beats and two dashes (--) will appear. After a moment, your heart rate will be shown. For the most accurate heart rate reading, continue to hold the handgrips for about 15 seconds.

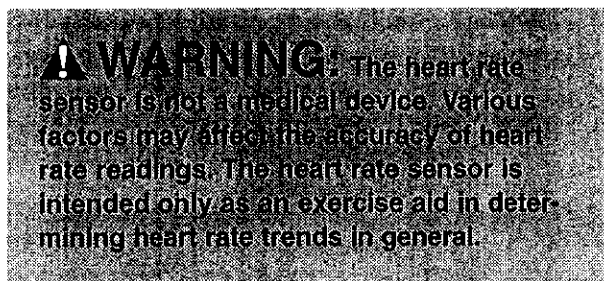

4. To turn off the power, simply wait for a few minutes. **The console has an "auto-off" feature. If the pedals are not moved and the console buttons are not pressed for a few minutes, the power will automatically turn off to conserve the batteries.**

MAINTENANCE AND TROUBLESHOOTING

Inspect and properly tighten all parts of the exercise cycle regularly. Replace any worn parts immediately.

To clean the exercise cycle, use a damp cloth and a small amount of mild soap. **Important: To avoid damage to the console, keep liquids away from the console and keep the console out of direct sunlight.**

PULSE SENSOR TROUBLESHOOTING

For optimal performance of the pulse sensor, keep the metal contacts clean. The contacts can be cleaned with a soft cloth—never use alcohol, abrasives, or chemicals.

Avoid moving your hands while using the pulse sensor. Excessive movement may interfere with heart rate readings. Do not hold the metal contacts too tightly; doing so may interfere with heart rate readings. For the most accurate heart rate reading, hold the metal contacts for about 15 seconds.

HOW TO ADJUST THE REED SWITCH

If the console does not display correct feedback, the reed switch should be adjusted. To adjust the reed switch, the left side shield must be removed.

First, remove the five M4 x 25mm Screws (39) from the Right Side Shield (16). Next, remove the M4 x 12mm Screw (57) from the right side of the Side Shield Cover (17).

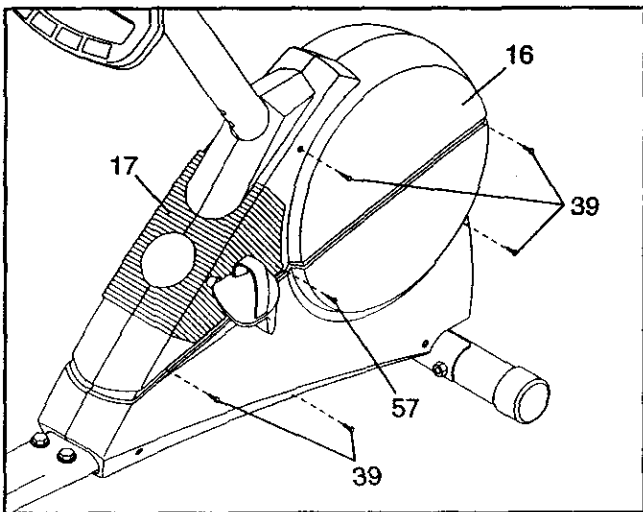

Using an adjustable wrench, turn the Left Pedal (20) clockwise and remove it. Next, remove the two M4 x 16mm Screws (40) from the Left Side Shield (15) and the M4 x 12mm Screw (57) from the Side Shield Cover (17). Lift off the Side Shield Cover and the Left Side Shield.

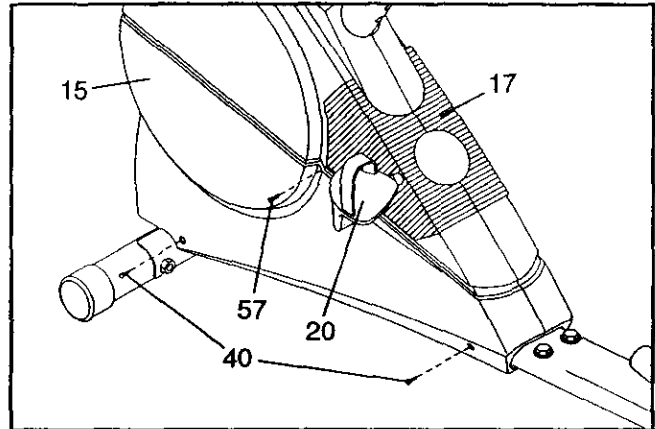

Next, locate the Reed Switch (46). Turn the left arm of the Crank (14) until the Magnet (58) is aligned with the Reed Switch.

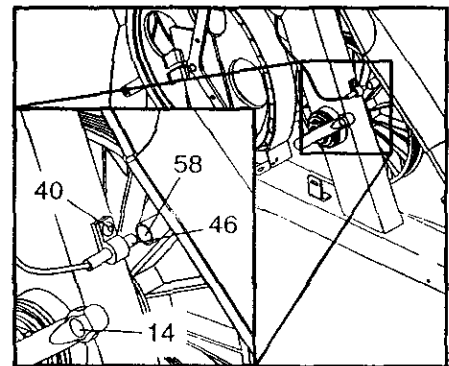

Loosen, but do not remove, the indicated M4 x 16mm Screw (40). Slide the Reed Switch slightly closer to or away from the Magnet. Retighten the Screw. Turn the Crank Arm for a moment. Repeat until the console displays correct feedback. When the Reed Switch is correctly adjusted, reattach the left side shield, the side shield cover, and the left pedal.

BATTERY REPLACEMENT

If the console display becomes dim, the batteries should be replaced; most console problems are the result of low batteries. To replace the batteries, refer to assembly step 8 on page 6 and remove the console from the upright. Next, refer to step 7 and insert three batteries into the console. Reattach the console to the upright. **Be careful not to pinch the wires or the cable.**

CONDITIONING GUIDELINES

The following guidelines will help you to plan your exercise program. Remember that proper nutrition and adequate rest are essential for successful results.

⚠ WARNING:

- Before beginning this or any exercise program, consult your physician. This is especially important for persons over the age of 35 or persons with pre-existing health problems.
- The pulse sensor is not a medical device. Various factors may affect the accuracy of heart rate readings. The pulse sensor is intended only as an exercise aid in determining heart rate trends. In general:

During the first few minutes of exercise, your body uses easily accessible *carbohydrate* calories for energy. Only after the first few minutes of exercise does your body begin to use stored *fat* calories for energy. If your goal is to burn fat, adjust the intensity of your exercise until your heart rate is near the lowest number in your training zone as you exercise. For maximum fat burning, adjust the intensity of your exercise until your heart rate is near the middle number in your training zone as you exercise.

Aerobic Exercise

If your goal is to strengthen your cardiovascular system, your exercise must be "aerobic." Aerobic exercise is activity that requires large amounts of oxygen for prolonged periods of time. This increases the demand on the heart to pump blood to the muscles, and on the lungs to oxygenate the blood. For aerobic exercise, adjust the intensity of your exercise until your heart rate is near the highest number in your training zone.

EXERCISE INTENSITY

Whether your goal is to burn fat or to strengthen your cardiovascular system, the key to achieving the desired results is to exercise with the proper intensity. The proper intensity level can be found by using your heart rate as a guide. The chart below shows recommended heart rates for fat burning, maximum fat burning, and cardiovascular (aerobic) exercise.

165	155	145	140	130	125	115	♥
145	138	130	125	118	110	103	♥
125	120	115	110	105	95	90	♥
20	30	40	50	60	70	80	

To find the proper heart rate for you, first find your age at the bottom of the chart (ages are rounded off to the nearest ten years). Next, find the three numbers above your age. The three numbers are your "training zone." The lowest number is the recommended heart rate for fat burning; the middle number is the recommended heart rate for maximum fat burning; the highest number is the recommended heart rate for aerobic exercise.

Fat Burning

To burn fat effectively, you must exercise at a relatively low intensity level for a sustained period of time.

WORKOUT GUIDELINES

Each workout should include the following three parts:

A warm-up, consisting of 5 to 10 minutes of stretching and light exercise. A proper warm-up increases your body temperature, heart rate, and circulation in preparation for exercise.

Training zone exercise, consisting of 20 to 30 minutes of exercising with your heart rate in your training zone. Note: During the first few weeks of your exercise program, do not keep your heart rate in your training zone for longer than 20 minutes.

A cool-down, with 5 to 10 minutes of stretching. This will increase the flexibility of your muscles and will help to prevent post-exercise problems.

EXERCISE FREQUENCY

To maintain or improve your condition, plan three workouts each week, with at least one day of rest between workouts. After a few months of regular exercise, you may complete up to five workouts each week, if desired. Remember, the key to success is make exercise a regular and enjoyable part of your everyday life.

SUGGESTED STRETCHES

The correct form for several basic stretches is shown at the right. Move slowly as you stretch—never bounce.

1. Toe Touch Stretch

Stand with your knees bent slightly and slowly bend forward from your hips. Allow your back and shoulders to relax as you reach down toward your toes as far as possible. Hold for 15 counts, then relax. Repeat 3 times. Stretches: Hamstrings, back of knees and back.

2. Hamstring Stretch

Sit with one leg extended. Bring the sole of the opposite foot toward you and rest it against the inner thigh of your extended leg. Reach toward your toes as far as possible. Hold for 15 counts, then relax. Repeat 3 times for each leg. Stretches: Hamstrings, lower back and groin.

3. Calf/Achilles Stretch

With one leg in front of the other, reach forward and place your hands against a wall. Keep your back leg straight and your back foot flat on the floor. Bend your front leg, lean forward and move your hips toward the wall. Hold for 15 counts, then relax. Repeat 3 times for each leg. To cause further stretching of the achilles tendons, bend your back leg as well. Stretches: Calves, achilles tendons and ankles.

4. Quadriceps Stretch

With one hand against a wall for balance, reach back and grasp one foot with your other hand. Bring your heel as close to your buttocks as possible. Hold for 15 counts, then relax. Repeat 3 times for each leg. Stretches: Quadriceps and hip muscles.

5. Inner Thigh Stretch

Sit with the soles of your feet together and your knees outward. Pull your feet toward your groin area as far as possible. Hold for 15 counts, then relax. Repeat 3 times. Stretches: Quadriceps and hip muscles.

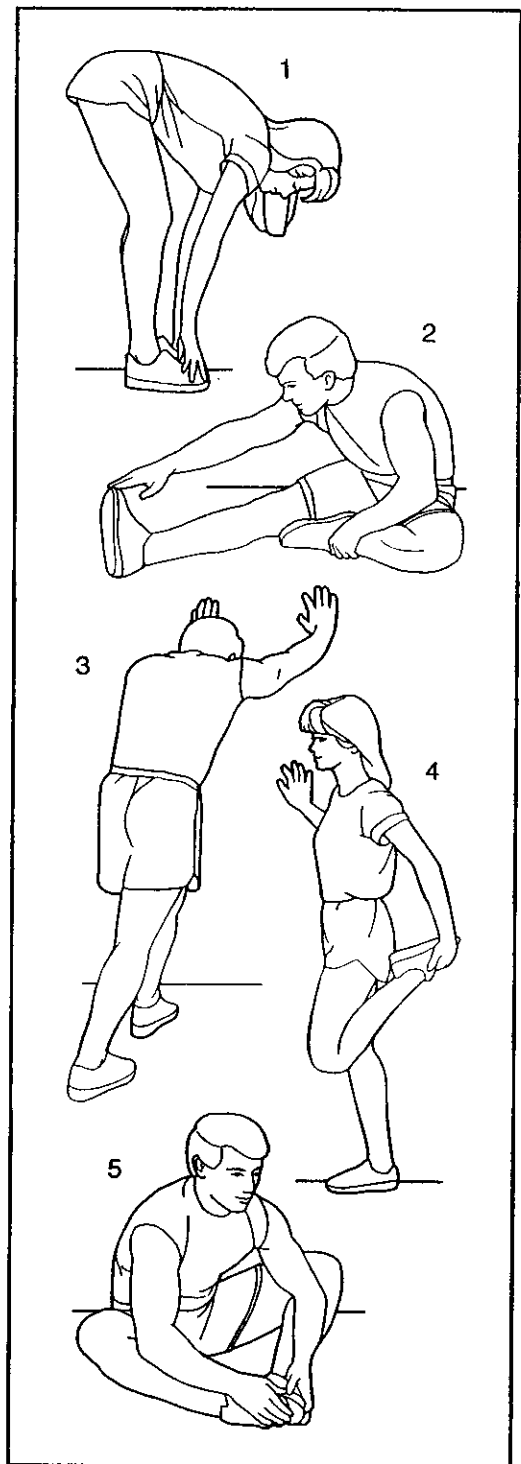

EXPLODED DRAWING—Model No. 831.283170

R0802A

Key No.	Qty.	Description	Key No.	Qty.	Description	Key No.	Qty.	Description
1	1	Frame	24	2	Foam Grip	47	4	M10 x 66mm Button Bolt
2	1	Front Stabilizer	25	1	Seat Carriage Endcap	48	2	M10 x 75mm Carriage Bolt
3	1	Frame Rail	26	1	Seat Knob	49	2	M10 x 80mm Button Bolt
4	1	Seat Carriage	27	1	Frame Rail Endcap	50	1	M6 x 25mm Bolt
5	1	Rear Stabilizer	28	1	"C" Magnet Bracket	51	1	"U" Bracket
6	1	Seat Frame	29	1	Crank Bearing Assembly	52	2	M6 Eyebolt
7	4	Stabilizer Endcap	30	1	M6 x 53mm Screw	53	2	M6 Nylon Locknut
8	2	Seat Carriage Bushing	31	1	Return Spring	54	3	M8 Nylon Locknut
9	1	Backrest	32	1	Lower Cable	55	1	M6 Large Washer
10	1	Seat	33	4	M6 Nut	56	1	Seat Endcap
11	1	Upright	34	1	Flywheel Axle	57	2	M4 x 12mm Screw
12	1	Console	35	2	Flywheel Bearing	58	1	Magnet
13	1	Flywheel	36	2	Flywheel Washer	59	1	Cable Clamp
14	1	Crank/Pulley	37	7	M6 x 16mm Screw	#	1	User's Manual
15	1	Left Side Shield	38	1	M6 Flat Washer	#	1	Allen Wrench
16	1	Right Side Shield	39	5	M4 x 25mm Screw			
17	1	Side Shield Cover	40	10	M4 x 16mm Screw			
18	1	Belt	41	8	M5 x 6mm Screw			
19	1	"C" Magnet	42	2	M10 x 52mm Button Bolt			
20	1	Left Pedal	43	8	M10 Split Washer			
21	2	Pedal Strap	44	6	M10 Nylon Locknut			
22	1	Right Pedal	45	1	Reed Switch Clamp			
23	1	Hook	46	1	Reed Switch/Wire			

Note: "#" indicates a non-illustrated part. Specifications are subject to change without notice. See the back cover of this manual for information about ordering replacement parts.

EXPLODED DRAWING—Model No. 831.283170

R0802A

15

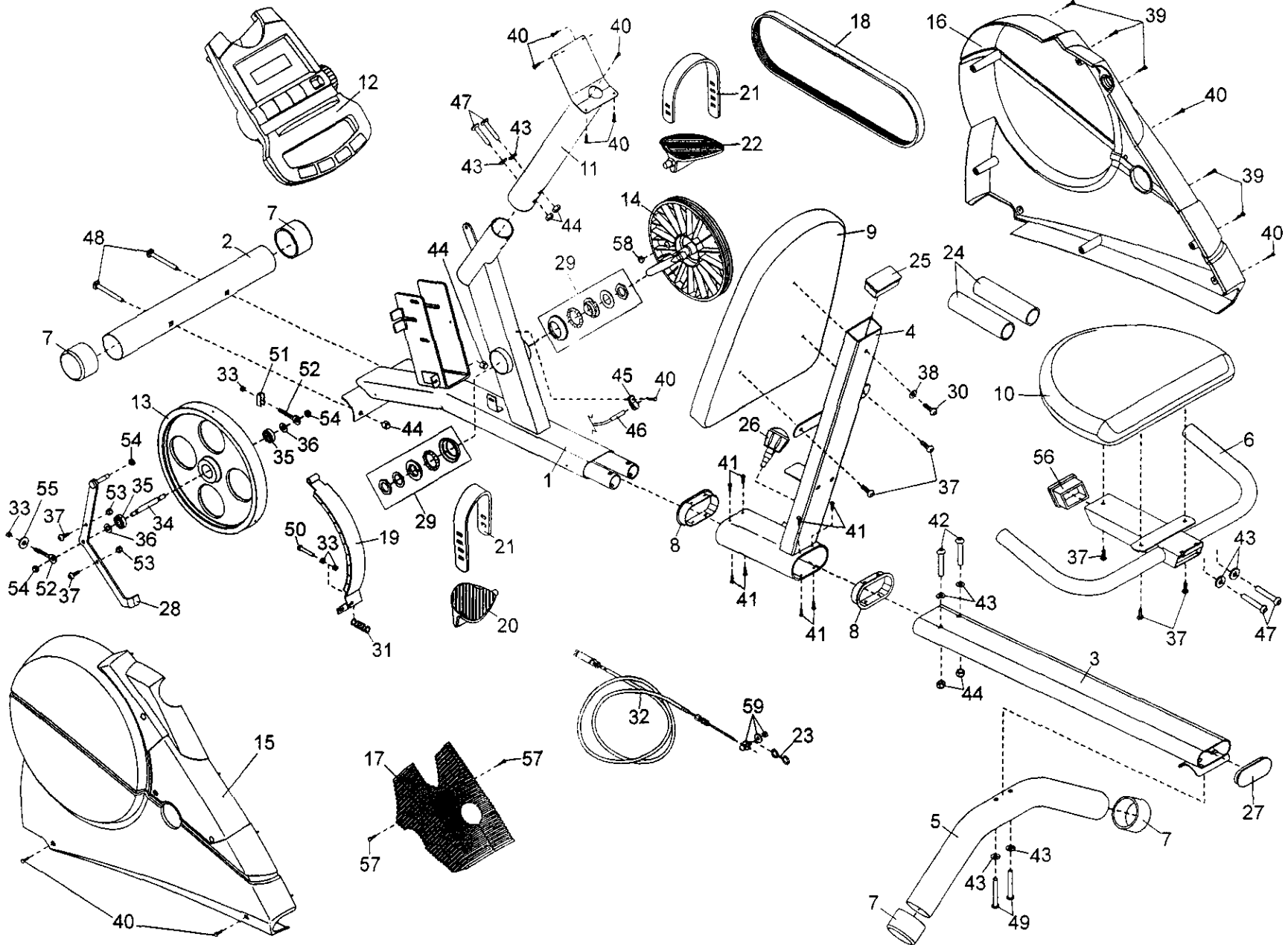



Model No. 831.283170

QUESTIONS?

If you find that:

- you need help assembling or operating the PROFORM® SR 23 exercise cycle
- a part is missing
- or you need to schedule repair service

call our toll-free HELPLINE

1-800-736-6879

Monday–Saturday, 7 am–7 pm
Central Time (excluding holidays)

REPLACEMENT PARTS

If parts become worn and need to be replaced, call the following toll-free number

**1-800-FON-PART
(1-800-366-7278)**

All replacement parts are available for immediate purchase or special order when you visit your nearest SEARS Service Center. To request service or to order parts by telephone, call the toll-free numbers listed at the left.

When requesting help or service, or ordering parts, please be prepared to provide the following information:

- The MODEL NUMBER of the product (831.283170)
- The NAME of the product (PROFORM® SR 30 exercise cycle)
- The KEY NUMBER and DESCRIPTION of the PART (see the PART LIST and the EXPLODED DRAWING on pages 14 and 15)

FULL 90 DAY WARRANTY

For 90 days from the date of purchase, if failure occurs due to defect in material or workmanship in this SEARS BIKE EXERCISER, contact the nearest SEARS Service Center throughout the United States and SEARS will repair or replace the BIKE EXERCISER, free of charge.

This warranty does not apply when the BIKE EXERCISER is used commercially or for rental purposes.

This warranty gives you specific legal rights, and you may also have other rights which vary from state to state.

SEARS, ROEBUCK AND CO., DEPT. 817WA, HOFFMAN ESTATES, IL 60179